

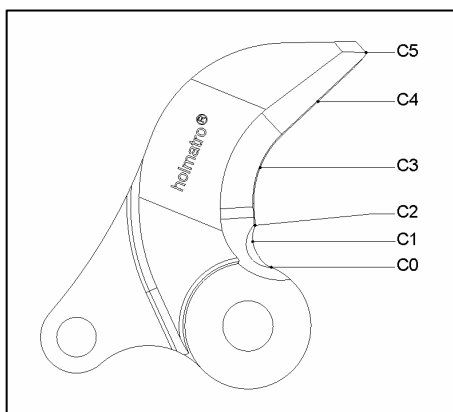

SPECIFICATIONS	
Article number	170.012.003
Equipped with	dual hoses
Working pressure	500 bar
Blade opening	158 mm
Cutting force, maximum	246 kN / 25.1 t
Weight, ready for use	14.6 kg
Dimensions (LxBxH)	696 x 243 x 177 mm
Temperature reach	-20° +80° C
Torque main bolt	100 Nm
Required oil content	84 cc (effective)

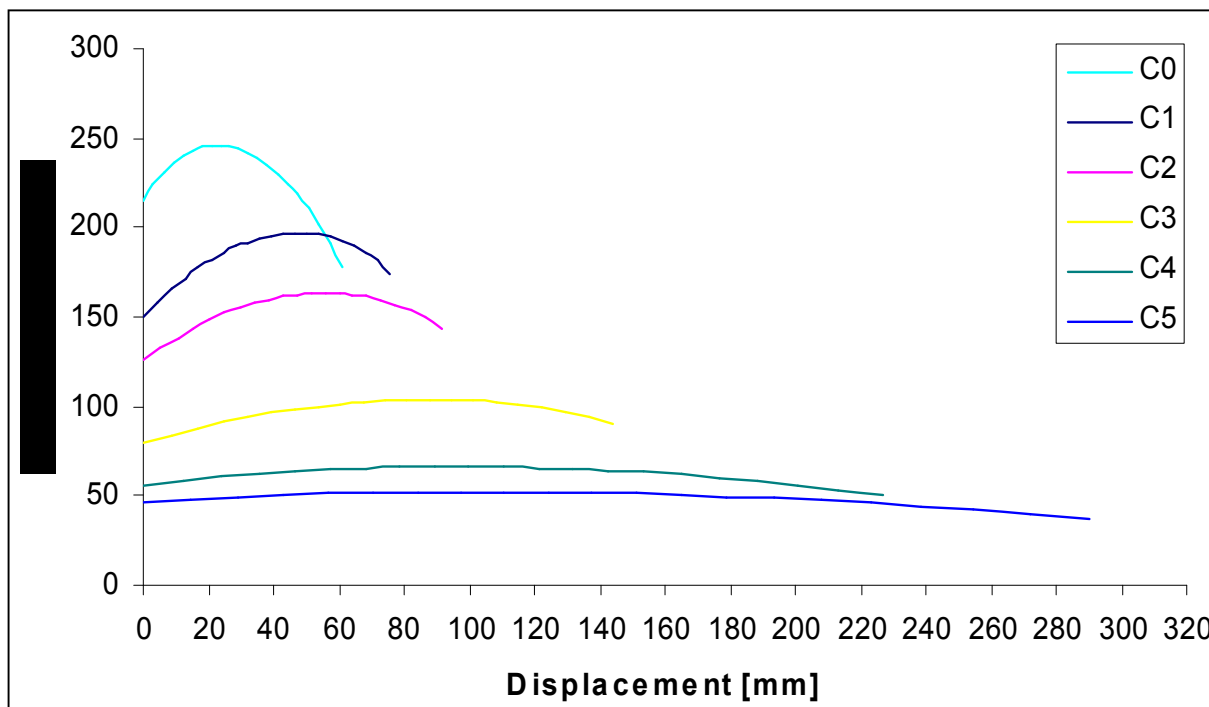

ACCESSORIES	Art.no.
Spare blade set	170.013.042
Maintenance set, cylinder	170.013.016
Maintenance set, control handle	170.013.050
Torque wrench, 40-200 Nm	150.581.671
Cap hexagon 41 mm	170.183.001
Tool set for changing the blades	150.582.543



Manufacturing sales & service worldwide

Holmatro Industrial Equipment
 P.O. Box 33, 4940 AA Raamsdonksveer
 The Netherlands
 T + 31 (0)162 - 58 92 00
 F + 31 (0)162 - 52 24 82
 E info@holmatro.com
 I www.holmatro.com

Manufacturing sales & service U.S.A., Canada and Latin America

Holmatro, Inc.
 505 McCormick Drive, Glen Burnie, MD 21061
 U.S.A.
 T + 1 - 410 - 768 - 9662
 F + 1 - 410 - 768 - 4878
 E info@holmatro-usa.com
 I www.holmatro-usa.com

© Holmatro® 10-07

While the greatest care has been devoted to the content, it is possible that the information in this printed matter is incorrect or incomplete. Holmatro N.V. and its affiliated companies (hereafter: Holmatro) cannot be held liable in any way for the consequences of activities undertaken on the basis of this printed matter. If you have any doubts about the correctness or completeness on the information, you shall contact Holmatro (phone number: +31 (0)162-589200).

Nothing from this printed matter can be copied and/or made public in any way without the explicit authorization of Holmatro

