



Holmatro

Foundry Tools

 **holmatro**
mastering power

CIS (Holmatro) Ltd, 25 Hatton Close, Moulton Park Ind. Est., Northampton, NN3 6SU. Tel:- +44(0) 1604 642020 | Fax:- +44(0) 1604 642323

Web:- www.700bar.com Mail:- sales@700bar.com

Mastering power

Holmatro products are all about the principle that only controlled power can be deployed effectively. We have expressed this vision in the slogan 'Mastering Power' which applies perfectly to both business units that together form the Holmatro Group.

Industrial Equipment is about applying and mastering high pressure power in heavy industrial applications. And with Rescue Equipment it is a matter of life and death for fire brigades and rescue organisations to work in a controlled, precise and well-thought-out way with the proper equipment.

www.holmatro.com



Scan the Holmatro
company movie



→ **Introduction**

About Holmatro	6
What Holmatro Stands For	7
Holmatro's Foundry Tools	8
Features Foundry Wedge	10

→ **Foundry Wedges**

Foundry Wedges	
Compact	12
Standard	14
Multi-Rotatable	16

Pump	18
-------------	----

Accessories	
Mobile Suspension Point	19
Balancers	20
Service Set	20
Parts	20

→ **Service & Safety**

Service & Safety	24
-----------------------------	----





About Holmatro

Holmatro, founded in the Netherlands in 1967, originally traded in high-pressure hydraulic tools for the shipbuilding industry. Nowadays we design, develop, manufacture and deliver hydraulic equipment and systems that are used for rescue, industrial and special tactics operations around the world. Our strategy, products and services are aimed at helping customers to succeed in mastering the power they need.

Foundry Tools

The publication you have before you is our Foundry Tools catalogue. It contains a number of foundry wedges for the nodular cast iron industry to remove feeders and risers from castings quickly and safely without damaging the casting itself, and with much less physical effort. Besides the more standard wedges we also offer multi-rotatable foundry wedges (R) that can be used at any working height. The unique construction of the suspension system enables the wedges to be positioned quickly, simply, ergonomically and in any required direction, including vertically.



Besides Foundry Tools, we also offer:

- **Industrial Tools;**

The extensive product range of Industrial Tools contains a large number of high-pressure hydraulic, pneumatic and mechanical tools. Used in various industrial applications, such as shipbuilding, heavy transport, maintenance, petrochemical, offshore, construction & installation, mining and civil engineering.

- **Industrial Solutions;**

Results-oriented customised hydraulic solutions for loads that are difficult to move with standard tools. This includes challenges relating to lifting, pushing, pulling, lowering, weighing, tilting and horizontal movement. We work closely with users to achieve the correct solution.

- **Industrial Cutting Tools;**

Cutting tools specially designed for cutting various materials. Mainly used in cable recycling, vehicles recycling, household appliances recycling and in various demolition industries.

- **Vehicle Rescue;**

Tools specially made for extricating victims who are trapped after road traffic accidents, involving personal vehicles, transport vehicles, public transportation or defence vehicles.

- **Disaster Response Rescue;**

Disaster Response Rescue solutions support rescuers to generate the immense forces needed during rescue activities after natural or man-made disasters.

- **Special Tactics;**

Tools designed for Special Tactics operations. These tools are equipped with features such as low visibility, quick and quiet operation and optimal portability.

Essential to all Holmatro products is the control of immense power. You must be able to rely on that for every application under any circumstances. To ensure this, regular maintenance and periodic certification is essential; as well as the deliberate and safe use of your hydraulic equipment. Working safely is not only more efficient but also contributes to the increased lifespan of the tools. Our tools are high quality and extremely durable, not least because of our extensive service program.

www.holmatro.com



What Holmatro Stands For

The power of innovation

In order to maintain our leading position as a specialist in high-pressure hydraulics, we continuously invest in research and product development. It is our ambition to continue to develop innovative solutions combining extreme power with controllability, user friendliness and safety. Our product development is fully focused on finding result-oriented solutions for specific markets and applications. To achieve this, we closely work together with you, the professional user.

Quality in everything we do

At Holmatro we work according to the ISO 9001 Quality Management Standard and the SCC* Safety Health and Environment (SHE) Checklist Contractors. Our products comply with all international standards such as the European EN 13204, EN 13731 and the American NFPA 1936. Holmatro tools are developed, manufactured and maintained in conformity with the highest quality standards of durability, side load, mechanical distortion and overpressure. As they must be resistant to the most extreme conditions, our products are thoroughly tested before they are authorised for use in practice.



(Inter)national sales network

Our experience of many years and in-house engineering enable us to provide you with expert advice on both our products and applications. Besides the head office in the Netherlands, Holmatro has manufacturing plants and sales offices in the Netherlands and the United States. We have representative offices in the People's Republic of China, the United Kingdom and Poland.

Our sales organisation and worldwide dealer network - fully trained in our own training centre - guarantee the same Holmatro standard of quality and a perfect after sales service for all our products.

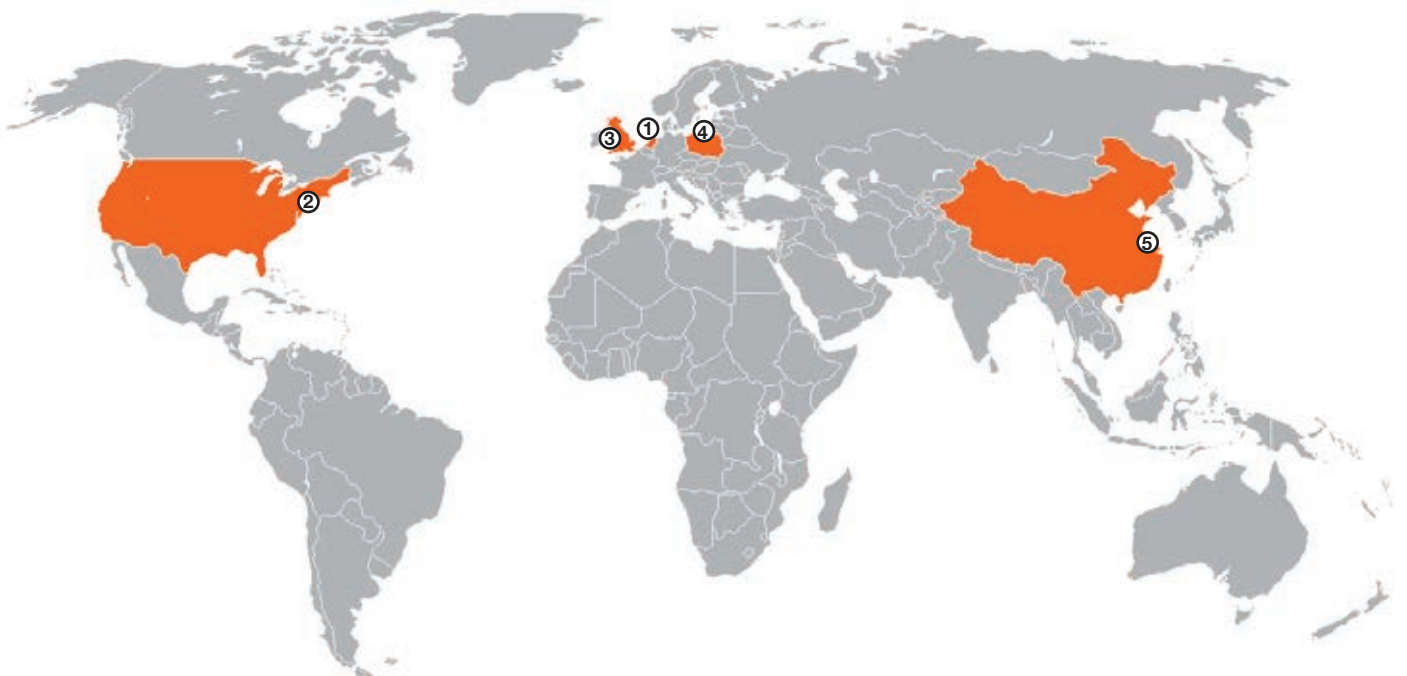

Holmatro **Netherlands**

Holmatro **USA**

Holmatro **UK**

Holmatro **Poland**

Holmatro **China**

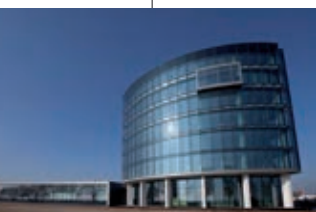

Holmatro's Foundry Tools

Our Foundry Tools are developed to remove feeders and risers from castings and to eliminate this heavy and dangerous work from foundries. Their design is such that feeders and risers can be removed from castings quickly and safely without damaging the casting itself, and with much less physical effort compared to the use of traditional hand tools.

A Holmatro foundry set consists of a foundry wedge, a pump, balancer and a service set. We understand that every foundry has its own specific needs. We therefore supply a range of tool and pump models to suit every requirement.





Ergonomics

During the design stage of the HFW foundry wedge, our engineers emphasised the tool's ergonomic aspects. The result: wedges implicating that the operator can reach almost any feeder and riser without repositioning the casting. The unique construction of the multi-rotatable wedge goes even further and is very suitable for the positioning in any required direction, including vertically. Both types avoid unnecessary heavy handling. Because the physical burden significantly reduces on your work force, a more efficient production process is the result.

Positioning

The standard wedge has two standard suspension points:

- Suspension point 1 positions the tool horizontally
- Suspension point 2 can be used for angular positions

The multi-rotatable wedge has a unique suspension construction that enables the wedge to be positioned in any required direction, including vertically.

Standard wedge

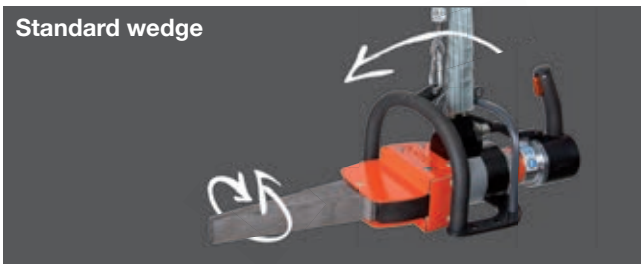

Multi-rotatable wedge

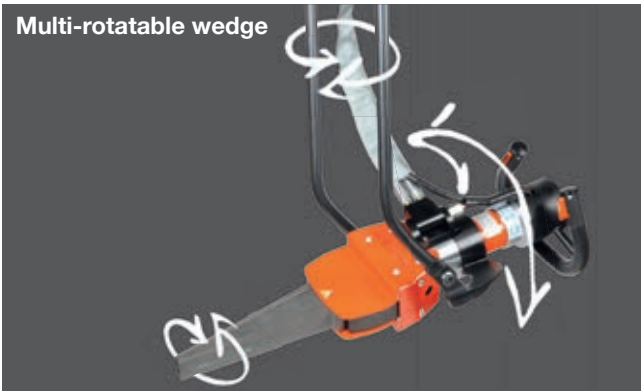

Quick and easy to use

The wedge blades of the Holmatro foundry wedge are durable and can be replaced very quickly. No tools are needed, only a few simple operations are sufficient to replace the blades within 30 seconds!

The pump unit can be activated by means of a push button on top of the tool's user-friendly handle. A high number of spreading cycles per minute allows for a high operation speed.



Safe to operate

Holmatro foundry wedges are outstanding in the safety of their operation. Attributes such as a full protection cover and the fact that the tool supports two-handed operation, greatly limit the chances of accidents happening.

Another feature is that the tool provides clean predictable cuts, guaranteeing that feeders and risers break off in a controlled manner.

Hydraulic Wedges

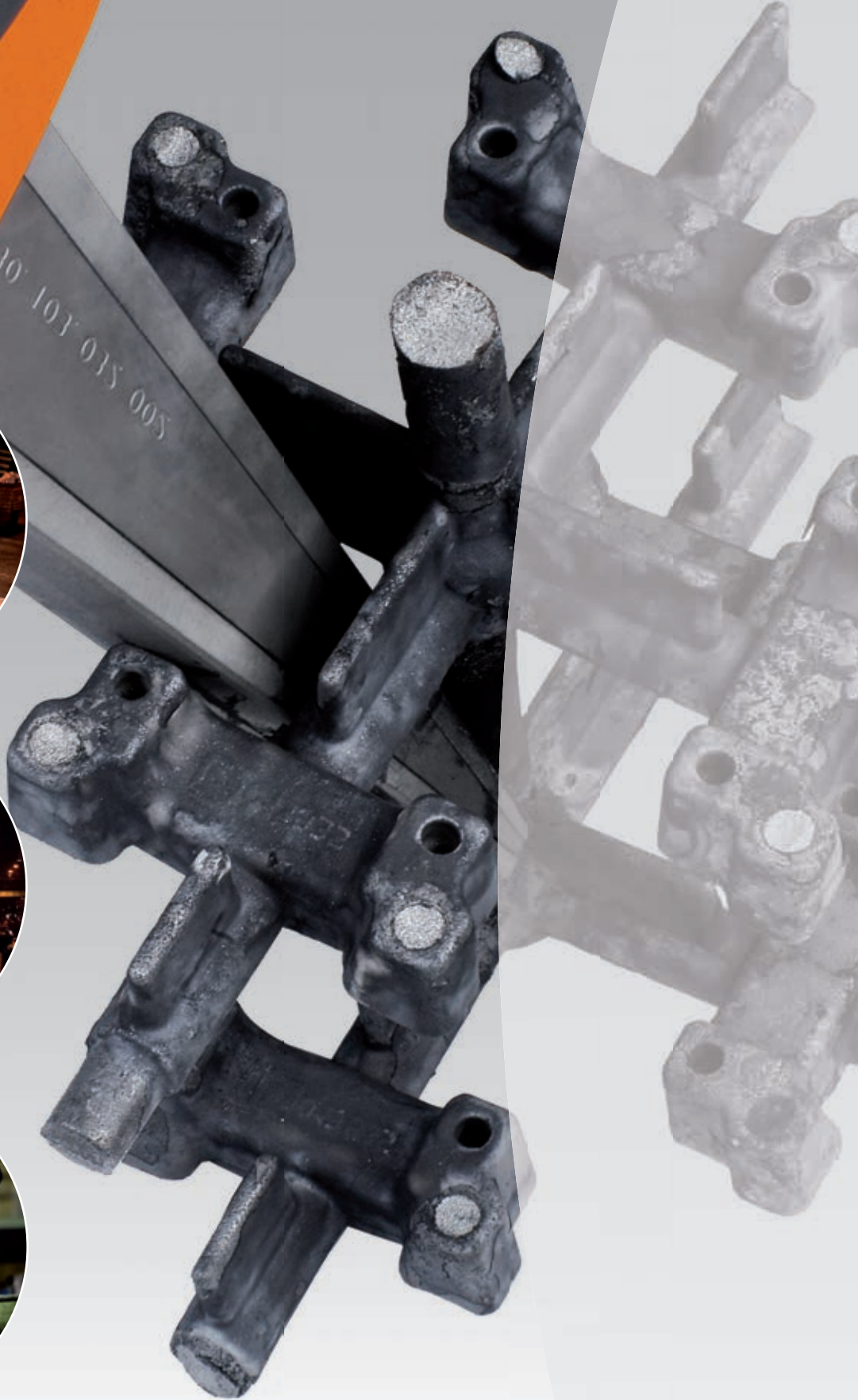



HFW 926

Features & benefits ↓

- User-friendly
 - Compact
 - Push-button operation
 - Rotating for easy positioning
 - Avoids heavy physical strain
- High working speed; large number of spreading cycles per minute without damaging the casting
- Powerful
- Safe
 - A clean, predictable “cut” prevents unnecessary shooting away of material and damage to the casting
 - Pistol grip for one-hand operation
 - Protection cover
 - The wedge is constructed of as few moving parts as possible
- Maintenance-friendly; durable wedge blades can be replaced within 30 seconds

Standard supplied with ↓

- Anti-friction coating Bel Ray (400 ml)
- Hand nut, T-grip (2 pieces)
- Service instructions (plasticized)

Available on request ↓

- Top handle
- Central wedge and wedge blades manufactured in conformity with customer specifications



Foundry Wedges - Compact



model		HFW 926
art no		130.102.005
max. working pressure	bar/Mpa	200 / 20
effective spreading	mm	26
min. insertion space	mm	10
wedge angle	°	19.6
wedge travel	mm	75
max. spreading force	kN/t	86 / 8.8
weight, ready for use	kg	19.6
riser size indication (grey iron)	mm	30
riser size indication (nodular iron)	mm	17

Foundry Wedges - Compact (dimensions)



model		HFW 926
dimension A	mm	10
dimension B	mm	50
dimension C	mm	156
dimension D	mm	30
dimension E	mm	322
dimension F	mm	482
dimension G	mm	36
dimension H	mm	76
dimension I	mm	99
dimension K	mm	511

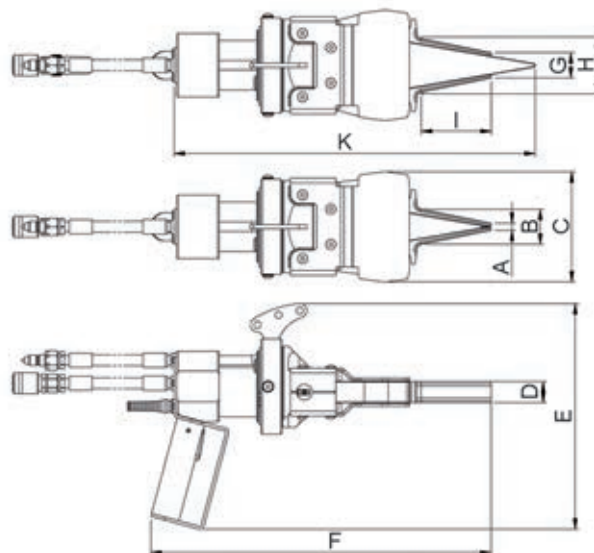



HFW 1518+

Features & benefits ↓

- User-friendly
 - Compact
 - Push-button operation
 - Rotating for easy positioning
 - Avoids heavy physical strain
- High working speed; large number of spreading cycles per minute without damaging the casting
- Powerful
- Safe
 - A clean, predictable “cut” prevents unnecessary shooting away of material and damage to the casting
 - Two-handed operation
 - Protection cover
 - The wedge is constructed of as few moving parts as possible
- Maintenance-friendly; durable wedge blades can be replaced within 30 seconds

Standard supplied with ↓

- Anti-friction coating Bel Ray® (400 ml)
- Hand nut, T-grip (2 pieces)
- Service instructions (plasticized)

Available on request ↓

- Central wedge and wedge blades manufactured in conformity with customer specifications

Pump	page	18
Accessories	page	19



Foundry Wedges - Standard

model		HFW 1226+	HFW 1518+	HFW 2426+	HFW 3018+
art no		130.102.016	130.102.013	130.102.015	130.102.012
max. working pressure	bar/Mpa	200 / 20	200 / 20	200 / 20	200 / 20
effective spreading	mm	26	18	26	18
min. insertion space	mm	19	23	29	30
wedge angle	°	15	10	15	10
wedge travel	mm	100	100	100	100
max. spreading force	kN/t	121 / 12.3	150 / 15.3	242 / 24.7	300 / 30.6
weight, ready for use	kg	39.0	42.7	42.2	48.3
riser size indication (grey iron)	mm	35	45	59	63
riser size indication (nodular iron)	mm	22	30	39	49

Foundry Wedges - Standard (dimensions)

model		HFW 1226+	HFW 1518+	HFW 2426+	HFW 3018+
dimension A	mm	19	23	29	30
dimension B	mm	69	91	74	127
dimension C	mm	358	358	358	358
dimension D	mm	44	44	50	50
dimension E	mm	266	266	273	273
dimension F	mm	766	902	731	871
dimension G	mm	46	40	55	48
dimension H	mm	95	109	101	145
dimension I	mm	147	278	133	275
dimension K	mm	672	804	632	775

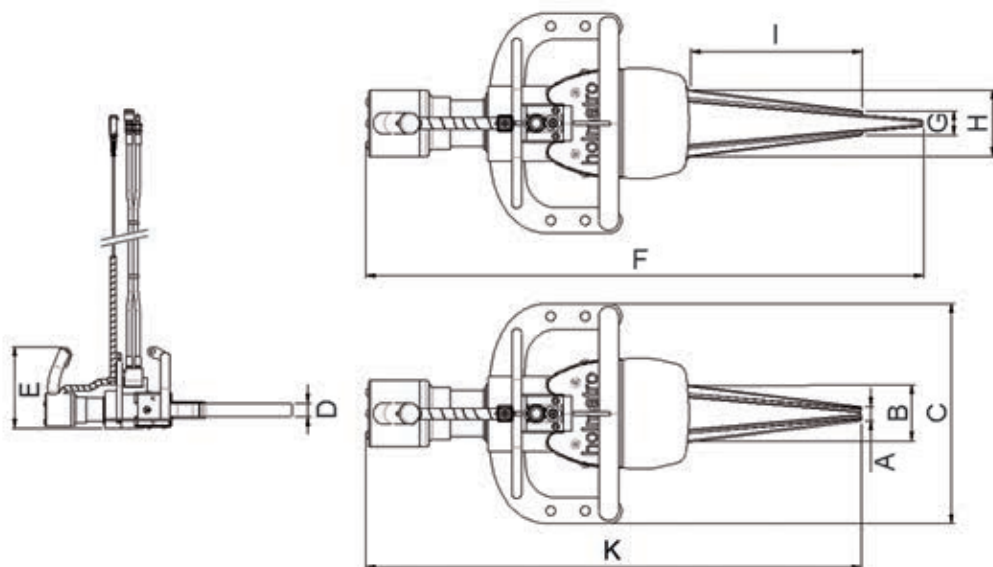



HFW 1518 R

Features & benefits ↓

- User-friendly
 - A unique suspension system for the optimum positioning of the wedge in any required direction
 - Handlebar-shaped operating handle for the flexible movement of the wedge
 - Suitable for both left-handed and right-handed users by means of a push-button control at each end of the operating handle
- High working speed; large number of spreading cycles per minute without damaging the casting
- Safe
 - A clean, predictable “cut” prevents unnecessary shooting away of material and damage to the casting
 - Handlebar-shaped operating handle supports two-handed operation
 - The wedge is constructed of as few moving parts as possible
- Maintenance-friendly; durable wedge blades can be replaced within 30 seconds

Standard supplied with ↓

- Anti-friction coating Bel Ray® (400 ml)
- Hand nut, T-grip (2 pieces)
- Service manual (plasticized)

Available on request ↓

- Central wedge and wedge blades manufactured in conformity with customer specifications

Pump	page	18
Accessories	page	19

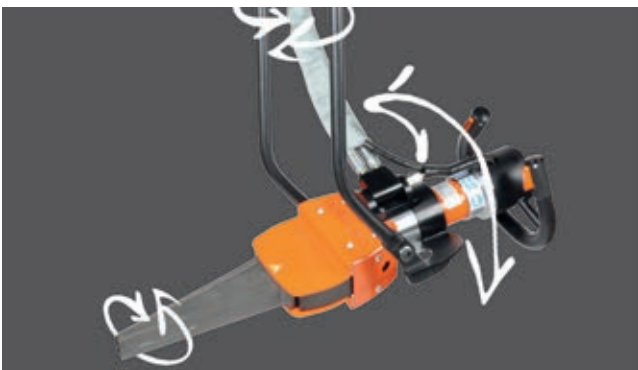

Foundry Wedges - Multi-Rotatable



model		HFW 1518 R	HFW 3018 R
art no		130.102.020	130.102.025
max. working pressure	bar/Mpa	200 / 20	200 / 20
effective spreading	mm	18	18
min. insertion space	mm	23	30
wedge angle	°	10	10
wedge travel	mm	100	100
max. spreading force	kN/t	150 / 15.3	300 / 30.6
weight, ready for use	kg	45.7	51.3
riser size indication (grey iron)	mm	45	63
riser size indication (nodular iron)	mm	30	49

Foundry Wedges - Multi-Rotatable (dimensions)



model		HFW 1518 R	HFW 3018 R
dimension A	mm	23	31
dimension B	mm	91	127
dimension C	mm	349	349
dimension D	mm	44	50
dimension E	mm	227	232
dimension F	mm	903	875
dimension G	mm	40	48
dimension H	mm	109	145
dimension I	mm	278	275
dimension K	mm	804	775

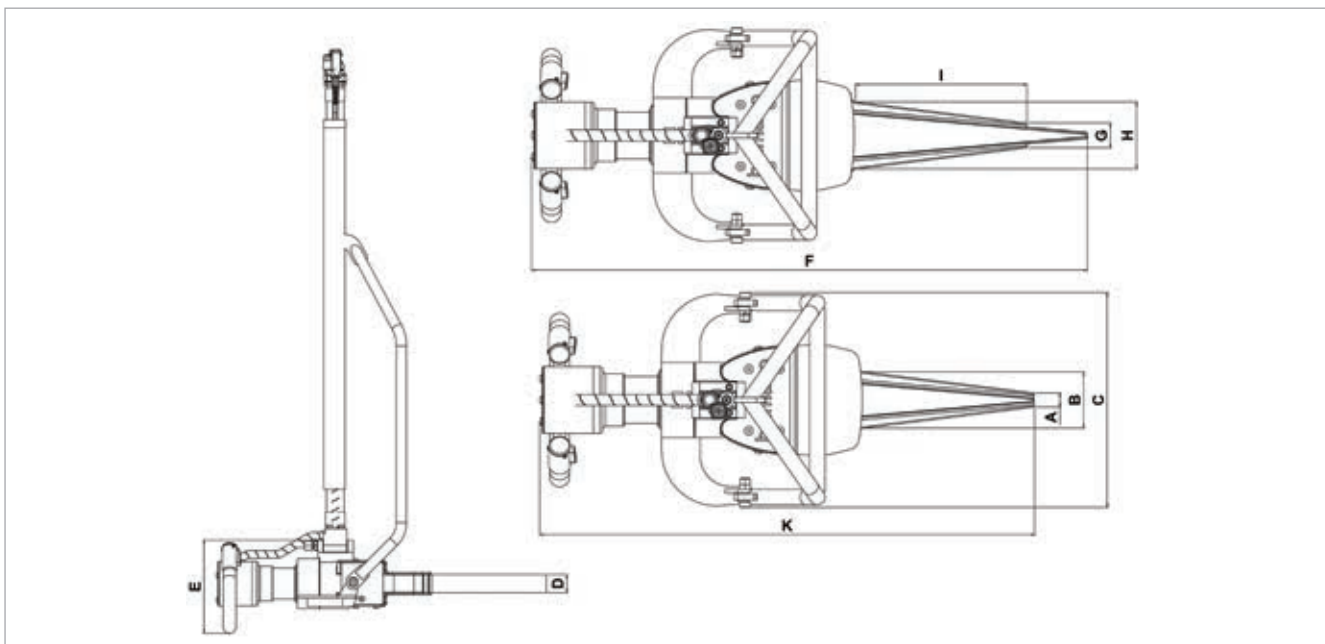



200 S 50 EN



Features & benefits ↓

- High operating speed
- Cycle counter
- Oil level indicator
- Oil temperature indicator
- Air / oil cooler
- Switch for wedge maintenance

Standard supplied with ↓

- 10 meter hose

Available on request ↓

- Foot pedal (electrical), art no 130.182.426
 - For foot operation of your foundry wedge
 - Replaces the electrical push-button operation of the foundry wedge

Pump ↓

model	200 S 50 EN	
art no	130.152.001	
max. working pressure	bar/Mpa	200 / 20
first stage output / min.	cc	20880
capacity oil tank (effective)	cc	50000
operator type	electric motor	
engine	400 VAC - 7.5 kW - 50 Hz - 3 Ph	
weight, ready for use	kg	190.0
dimensions (LxWxH)	mm	800 x 580 x 930
temperature range	°C	0 + 60

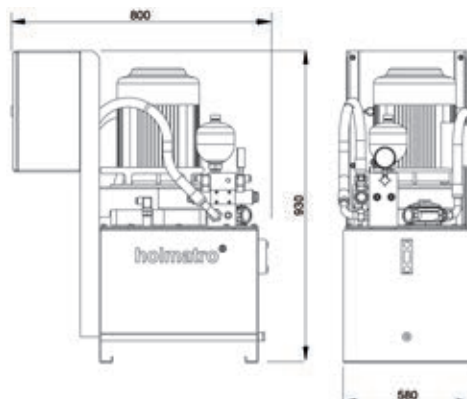



HMP 3-125

Features & benefits



- Long reach; flexible positioning of the wedge
- Stable construction; adjustable feet under the crane
- Easy to move with a forklift
- Safe; cutout in the base plate prevents movement of the pump

Accessories - Mobile Suspension Point



model	HMP 3-125	
art no	100.003.180	
max. weight capacity	kg	125.0
weight, ready for use	kg	620.0



Accessories - Mobile Suspension Point (dimensions)

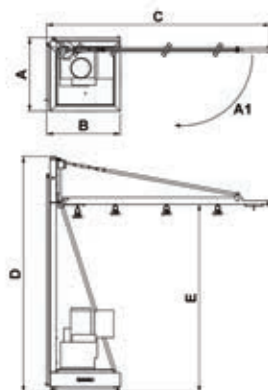

model	HMP 3-125	
dimension A	mm	1080
dimension B	mm	1080
dimension C	mm	3271
dimension D	mm	3455
dimension E	mm	2754
angle A1	°	110



Accessories - Balancers

image	description	model	art no
	Balancer, 15 - 20 kg • For ICU 10 / 40 & HFW 926 • For virtually weightless operation of the cutter or wedge	-	130.182.039
	Balancer, 35 - 45 kg • For HFW 1226+, 1518 & 2426+ • For virtually weightless operation of the cutter or wedge	-	130.581.003
	Balancer, 45 - 55 kg • For HFW 3018 • For virtually weightless operation of the cutter or wedge	-	130.102.007







Accessories - Service Set

image	description	model	art no
	Consists of: • Anti friction coating Bel Ray® (400 ml) • Handnut, T-grip (2 pieces) • Service instructions (plasticized)	-	130.013.001

Accessories - Parts

image	description	model	art no
	Wedge Blade HFW 926 (2 needed).	HFW 926	130.000.135
	Wedge Blade HFW 1226+ (2 needed).	HFW 1226+	130.000.038
	Wedge Blade HFW 1518 (2 needed).	HFW 1518	130.000.039

Accessories - Parts

image	description	model	art no
	Wedge Blade HFW 2426+ (2 needed).	HFW 2426+	130.000.040
	Wedge Blade HFW 3018 (2 needed).	HFW 3018	130.000.041
	Central Wedge for Foundry Wedge 926.	HFW 926	130.000.134
	Central Wedge for Foundry Wedge HFW 1226+.	HFW 1226+	130.103.031
	Central Wedge for Foundry Wedge 1518.	HFW 1518	130.103.032
	Central Wedge for Foundry Wedge HFW 2426+.	HFW 2426+	130.103.045
	Central Wedge for Foundry Wedge HFW 3018.	HFW 3018	130.103.067

